

PuROTwist Limited Warranty

International Water Warehouse warrants its PuRO Twist Model 4000 Reverse Osmosis system to be free from defects in materials and workmanship under normal use within the operating parameters listed below. For a period of five years from the date of purchase International Water Warehouse will repair or replace any part of the Reverse Osmosis System with the exception of the filters, membrane and battery. The RO membrane carries a 12 month warranty.

Conditions of Warranty

The above warranty shall not apply to any part of the International Water Warehouse Reverse Osmosis System that is damaged because of neglect, misuse, alteration, accident, misapplication, physical damage, fouling, and/or scaling of the membrane by minerals, bacterial attack, sediment or damage caused by fire, freezing, hot water, or an Act of God.

International Water Warehouse assumes no warranty liability in connection with this Reverse Osmosis System other than as specified herein. International Water Warehouse shall not be liable for consequential damages of any kind or nature due to the use of International Water Warehouse products.

Warranty Service

Warranty service will be provided by International Water Warehouse under the following conditions:

- 1) Contact your local International Water Warehouse dealer who will obtain return authorization instructions from International Water Warehouse.
- 2) Ship the unit or part freight prepaid to International Water Warehouse for warranty evaluation or service. Unit must be returned in the original carton or packaged to prevent possible damage. Systems or parts covered under the warranty shall be repaired (or, at our option replaced) and returned without charge.

CONDITIONS FOR OPERATION

Source Water Supply - TFC	
Community/Private	Non-Chlorinated
System Pressure	30-100 psi
Temperature	4°-38° C (40°-100° F)
pH Range	3.0-11.0
Maximum Supply TDS Level	2000 mg/L
Turbidity	<1.0 Net Turbidity (NTU)

Source Water Supply - CTA	
Community/Private	Chlorinated
System Pressure	30-100 psi
Temperature	4°-32° C (40°-90° F)
pH Range	4.0-8.0
Maximum Supply TDS Level	1500 mg/L
Turbidity	<1.0 Net Turbidity (NTU)

Chemical Parameters - TFC	
Hardness (CaCO ₃)	<350 mg/L (<20 gpg)
Iron (Fe)	<0.1 mg/L
Manganese (Mn)	<0.05 mg/L
Hydrogen Sulfide (H ₂ S)	0.00 mg/L
Chlorine (Cl ₂)	0.00 mg/L

Chemical Parameters - CTA	
Hardness (CaCO ₃)	<350 mg/L (<20 gpg)
Iron (Fe)	<0.1 mg/L
Manganese (Mn)	<0.05 mg/L
Hydrogen Sulfide (H ₂ S)	0.00 mg/L
Chlorine (Cl ₂)	0.1-10.0 mg/L

IWW
The International Water Warehouse
Santa Barbara, California



PuROTwist Reverse Osmosis Systems Model PT-3000, Model PT-4000 and Model PT-4000P



Installation and Service Guide

PLEASE READ THIS MANUAL CAREFULLY BEFORE ATTEMPTING INSTALLATION

INSTALLATION AND SERVICE GUIDE

Introduction

Read this entire service guide before beginning installation.

This Reverse Osmosis Drinking Water System has been designed for quick and simple installation and maintenance. By carefully reading this instruction manual and following the operational guidelines you will insure a successful installation and reliable operation. Routine maintenance is essential to the longevity and performance of the system. Filters should be changed every six to twelve months depending on the quality of the feed water supply.

CONDITIONS FOR OPERATION

TFC - Thin Film Composite

Source Water Supply - TFC	
Community/Private	Non-Chlorinated
System Pressure	30-100 psi
Temperature	4°-38° C (40°-100° F)
pH Range	3.0-11.0
Maximum Supply TDS Level	2000 mg/L
Turbidity	<1.0 Net Turbidity (NTU)

CTA - Cellulose Tri-Acetate

Source Water Supply - CTA	
Community/Private	Chlorinated
System Pressure	30-100 psi
Temperature	4°-32° C (40°-90° F)
pH Range	4.0-8.0
Maximum Supply TDS Level	1500 mg/L
Turbidity	<1.0 Net Turbidity (NTU)

Chemical Parameters - TFC	
Hardness (CaCO ₃)	<350 mg/L (<20 gpg)
Iron (Fe)	<0.1 mg/L
Manganese (Mn)	<0.05 mg/L
Hydrogen Sulfide (H ₂ S)	0.00 mg/L
Chlorine (Cl ₂)	0.00 mg/L

Chemical Parameters - CTA	
Hardness (CaCO ₃)	<350 mg/L (<20 gpg)
Iron (Fe)	<0.1 mg/L
Manganese (Mn)	<0.05 mg/L
Hydrogen Sulfide (H ₂ S)	0.00 mg/L
Chlorine (Cl ₂)	0.1-10.0 mg/L

CAUTION

DO NOT USE THIS SYSTEM WHERE THE WATER IS MICROBIOLOGICALLY UNSAFE OR OF UNKNOWN QUALITY. THIS SYSTEM IS FOR USE ON POTABLE WATER ONLY. SOURCE WATER EXCEEDING CHEMICAL PARAMETERS REQUIRES PRETREATMENT.

Activation, Troubleshooting, Maintenance

Activating the System For the First Time

Make sure all water supply/drain lines are secure and free from leakage.

Slowly turn the saddle valve counterclockwise until fully open. Check stem seal for leakage. If necessary tighten stem nut lightly.

Turn storage tank valve one quarter turn

counterclockwise to open the valve (the handle should be in line with the tubing as it enters the connection).

Open the product water faucet and let the water flow until all the air has been expelled from the system. This will take about an hour.

Close the product water faucet. In 30 minutes, check the connections for leaks and correct if necessary.

Do Not Use the First Two Reservoirs of Water

Allow the reservoir to fill for 4-6 hours. Dispense this water to drain. This process removes the factory installed sanitizing solution from the entire system and sends it to the drain. Repeat this process one more time. Allow the tank to fill for 4-6 hours and dispense this water to the drain.

Maintenance- Imperative to follow the sequence as outlined

Note that filters are labeled for easy servicing.

- 1) Open the RO faucet and let the tank drain completely. Leave the faucet open until the filter change is complete.
- 2) Remove the pre-sediment cartridge - Simply turn the pre-sediment cartridge counterclockwise and remove it (Models PT-3000, PT-4000, and PT-4000P). This will automatically shut off the water supply at the RO.
- 3) Remove the pre-carbon cartridge - Simply turn the pre-filter counterclockwise and remove it (Models PT-4000, and PT-4000P).
- 4) Remove the membrane cartridge - The membrane may be reused indefinitely as long as the TDS level and other troubleshooting guidelines are met.
- 4) Remove the post-carbon cartridge - Simply turn the post-carbon cartridge counterclockwise and remove it (Models PT-3000, PT-4000, and PT-4000P).
- 5) Install the new filters in the opposite order from removal. Note: PT-3000 has no pre-carbon cartridge.
- 6) Install the new pre-filter cartridge last. This will automatically turn on the system.
- 7) Drain the first tank of water after changing the filters before drinking. When the membrane is changed, drain the first two tanks of water before drinking.



Troubleshooting

Water has an offensive taste and/or odor	Carbon post filter is depleted	Drain storage tank and replace post filter
Water has an offensive taste and/or odor	Sediment/Carbon filters are depleted	Replace filters, clean system
Water has an offensive taste and/or odor	Membrane depleted or fouled	If monitor indicates red light, drain storage tank, replace membrane, sanitize system
Not enough product water pressure	Storage tank air pressure charge is low	Empty storage tank and set pressure to 8 psi (55 kPa)
Not enough water	Low water pressure	If line pressure is below 30 psi add a booster pump
Not enough water	Water supply is blocked	Clear restriction, rotate valve on feed water valve
Not enough water	Storage tank is depleted	Consider an increase in tank or membrane capacity
Not enough water	Clogged pre-filter cartridge	Replace prefilter, drain tank and sanitize system
No drain water	Clogged flow restrictor	Replace membrane
No water	Water supply is turned off	Turn water on
Under sink is wet	Leak from valve, faucet or fitting	Dry everything with towels to isolate leak, identify, and fix
Red service light	Depleted membrane or low usage	Run faucet for 10 seconds and check again, if persists, change membrane



Source & Drain Water Saddle Valve

Shut Off the Water

Locate the water shut-off valve for the cold water feed line you choose to use for the supply. Accidentally hooking up the system to the hot supply line will permanently damage the membrane (See Conditions for operation). To assure you are using the cold water line, turn on both the hot and cold faucet. After the water is warm to the touch, feel the pipes under the sink. It will be easy to identify the hot and cold pipes.

Close the cold water valve. Turn on the cold water faucet only to assure that the line is completely shut off and the line is drained.. If no shut off valve is located under the sink, turn off the main supply at the entry to the house.

Place the clamp over the cold water supply line. The aluminum spacer has two sides to adapt to different tubing sizes. Use the small radius for 3/8" tubing and the large radius through 5/8". Use the clamp screw to attach the saddle to the copper pipe. Tighten the brass clamp screw with a 7/16" wrench.

Do not crush the tubing

Do not over tighten the clamp. The clamp should be secure and resist a slight twisting force.

Turn the saddle tapping valve clockwise until the needle fully pierces the tubing and the valve seats. For maximum flow, back the handle out all the way. Adjust as required.

Check for Leaks

Turn on the cold water supply. Check the saddle tapping valve for leaks. Allow the water to run for a minute to clear any possible debris from the saddle tapping device.

If flow from the faucet is reduced, remove, clean, and reinstall the faucet aerator.

1/4" SELF PIERCING SADDLE VALVE

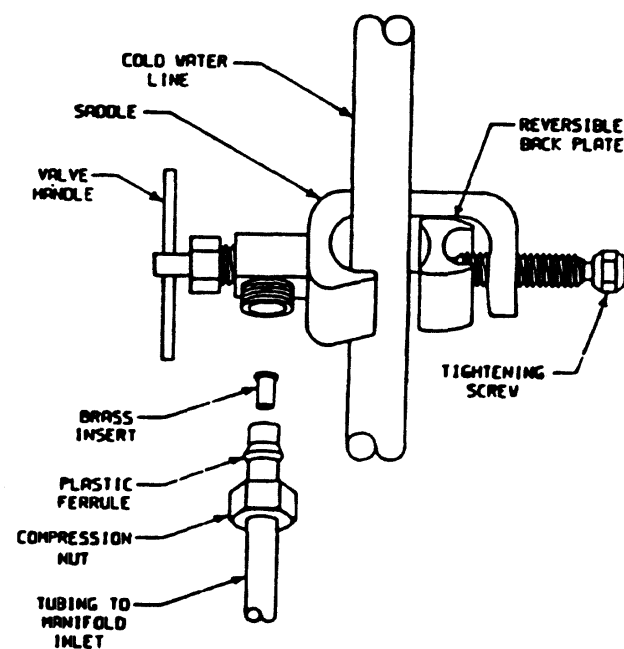

Installing the Drain Clamp

Select a location for the drain hole based on the design of the plumbing. Position the drain outlet saddle on the drain pipe. Allow adequate space for drilling. Tighten the bolts evenly on both sides. Avoid overtightening.

Using the opening in the drain outlet saddle as a guide, drill a 1/4" hole in the drain pipe. Clean debris from the saddle and threads.

NOTE: Some states require the use of an air gap faucet. Check your local plumbing code to assure compliance. Locate the drain connection away from the garbage disposal to prevent potential contamination and system fouling.

DRAIN CLAMP ASSEMBLY

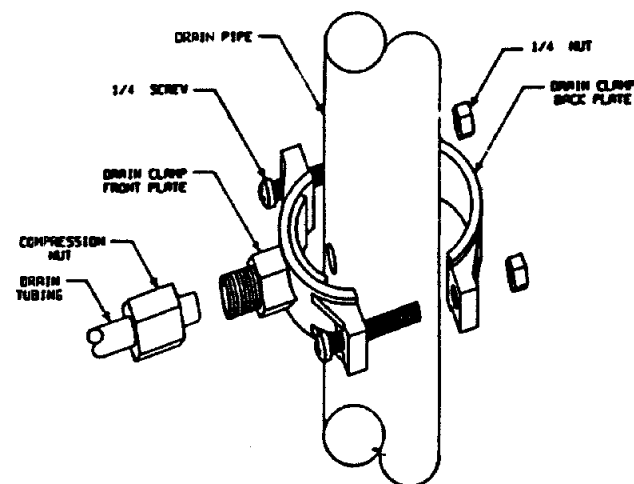

Starting Your Installation



Preparation

Check the following list of components to ensure that all parts are packed with your system.

- 1 - Storage Tank
- 1 - RO System
- 1 - Faucet
- 1 - Installation Kit

Determine the location for the storage tank. A maximum distance from tank to faucet of 15 feet is possible. The system will produce a faster flow at the faucet with the shortest tubing run from tank to faucet.

Determine the location for the installation of the RO system. Avoid locations where the system might come in contact with hot water pipes or other hazards.

Determine the location for the faucet. Check to see that drilling the faucet hole will not damage pipes or wires running underneath the sink.

All tubing is individually labeled and color coded for ease of installation.
1/4" Red - Connects the feed water valve to the RO pre-filter
3/8" Blue - Connects the RO membrane product port to the storage tank
1/4" Black - Connects the membrane brine port to the drain connector
3/8" White - Connects the postfilter to the faucet

Fittings and Tubing

John Guest™ fittings are used throughout the system. To insure a optimal seal, tubing should be cut with the end square. An angled cut or distortion of the tubing will not provide an efficient seal and may cause leaks.

To install a tube, push it through the collet until it seats firmly. To remove a tube, push in the collet and pull out the tube.

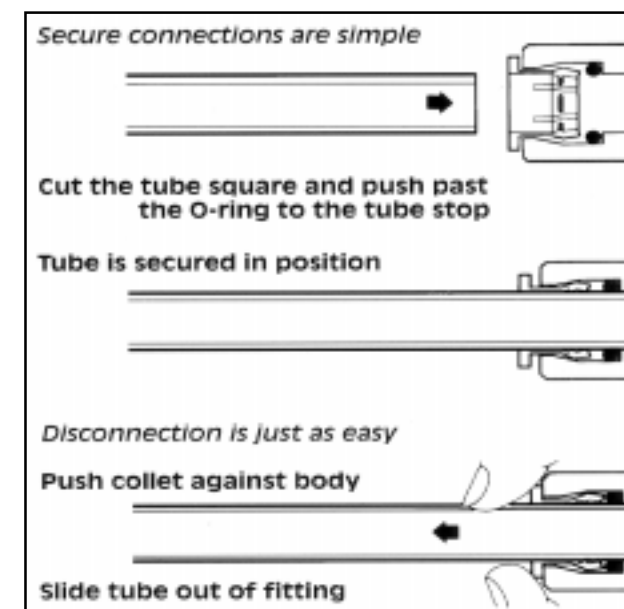

Drilling the Faucet Hole

The product water faucet may be installed on any flat surface at least 2" in diameter. Check the underside of the location for interference.

Porcelain/Enamel Sinks

A 3/8" variable speed drill is recommended for this procedure.

A spring loaded Relton style drill set is strongly recommended to prevent chipping.

The plastic sleeve supplied on the pilot drill is to be positioned on the drill bit against the drill chuck. This prevents the chuck from contacting the porcelain after the pilot hole has been completed.

Avoid high motor RPM during the initial cutting of the porcelain as this can cause chipping.

Using a carbide tipped drill bit, drill a pilot hole completely through the porcelain and the material underneath.

Place the spring loaded porcelain saw into the drill chuck. Make sure the pilot guide is inserted tightly. Insert the pilot guide into the pilot hole. Push down gently on the drill motor to apply light pressure to the porcelain surface. Start the drill motor turning as slowly as possible.

After the initial cut has started, motor speed may be gradually increased. The cut may require three to four minutes to complete. Going faster could result in excessive chipping.

Be sure a complete ring has been cut through the porcelain to the material underneath.

Place the finish hole saw into the drill chuck. Make sure the pilot guide is inserted tightly. Insert the pilot guide into the pilot hole. Begin cut using a slow speed and light pressure until the porcelain has been penetrated to the material underneath.

Stainless Steel Sink

Make a small indent to mark the desired drilling location using a center punch. Drill a pilot hole with a 1/8" metal drill bit. Enlarge the hole using a 3/8" metal drill bit.

Tile Counter Top

Follow the procedures outlined in the Porcelain/Enamel Sinks section.

Faucet Installation

Once the hole has been drilled in the sink, the faucet may be located in the hole. Be sure the faucet body, faucet base, and the rubber faucet base washer are in place above the sink.

Install the star lock washer and nut, then tighten firmly while aligned faucet in the desired direction.

Additional Point of Use Connection

NOTE: Ice makers typically use 1/4" tubing as the water feed line. Use a reducing union fitting to make this connection

To connect an additional point of use (icemaker, extra faucet, etc.), place a 'T' connector in the 3/8" line between the faucet and the RO system.

Drilling with the recommended Relton cutter

EASY AS ...

